



Sampling Ball Valve

S4

PVDF

DATASHEET

Overview

General		
Material	Body material Seal material Ball Seat	PVDF FPM PTFE
Dimensions	DN6	
Connector types	Body Hose nozzle (Male Thread) Hose nozzle (Female Thread) Double nipple Plug	BSP / NPT BSP / NPT BSP / NPT BSP / NPT NPT / NPT BSP
Operating pressure	DN6	PN10

Technical data

Pressure – temperature – diagram

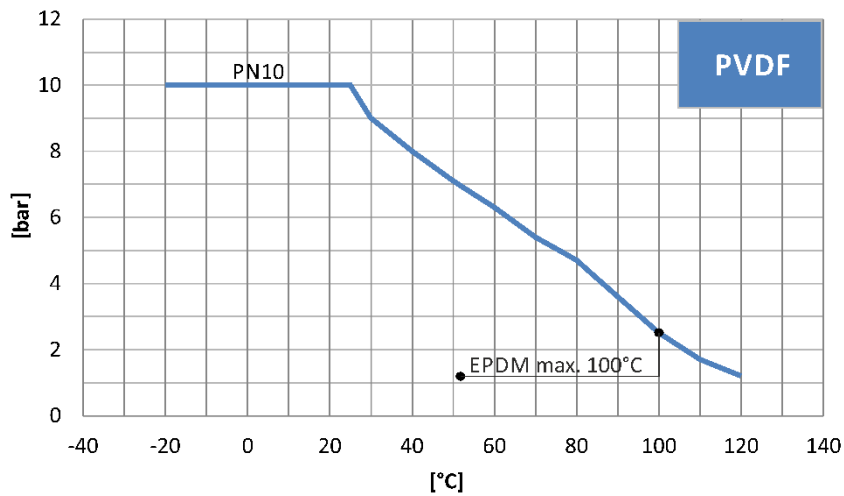

Flow characteristics

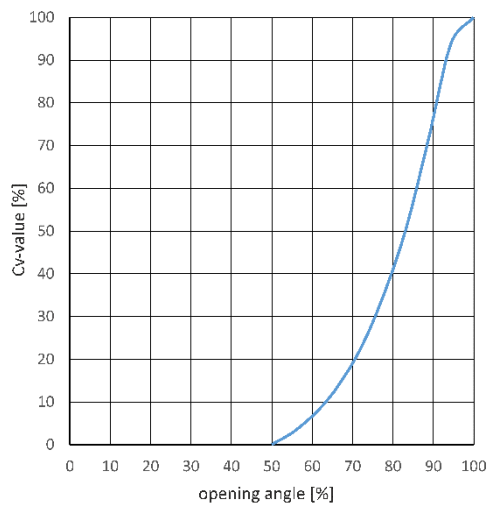

Kv-value-table

Pressure loss	DN6
1,0 bar	2,17

specification in l/min (PN16 pipe)

The values of the pressure-temperature-diagram are based on a service life of 25 years at static pressure load and apply to water or water-like media.

Additional features:



When not in use, lock and metering ring can be hanged on sampling ball valve body

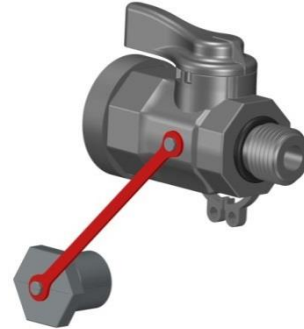

When not in use, plug can be fixed with the clip tie on the sampling ball valve body.

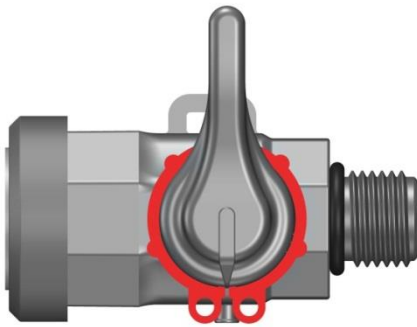

In closed position, the lock and metering ring protects the valve against unwarranted opening.

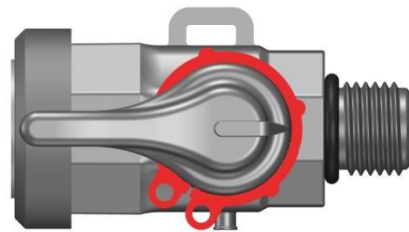

In open position, the locking ring protects the valve against unwarranted closing.



The sampling ball valve can be installed on the pipeline with a wrench SW22 or SW24.



The three metering marks serves as guidance for flow regulation.

Dimensions hand operated

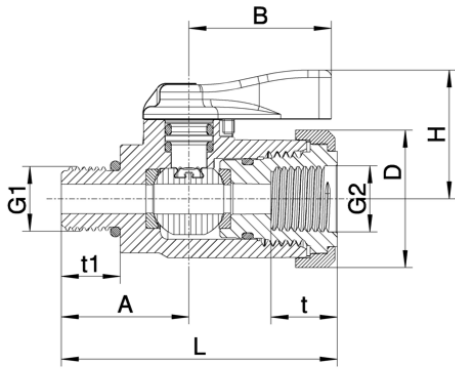

Laboratory ball valve

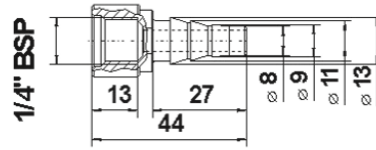

Hose nozzle female thread

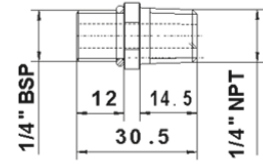

Double nipple

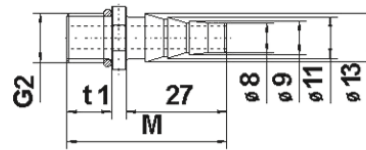

Hose nozzle male thread



Plug

(dimensions in mm)

G1	G2*	A	B	D	H	L	M	N	t	t1	PN
1/4" BSP	1/4" BSP	26	28,2	28	26	56	43	16	13,2	12	10
1/4" NPT	1/4" NPT	28,5	28,2	28	26	58,5	45,5	18,5	13,2	14,5	10

*No standard thread, thread is based on BSP and NPT

Exploded drawing hand operated

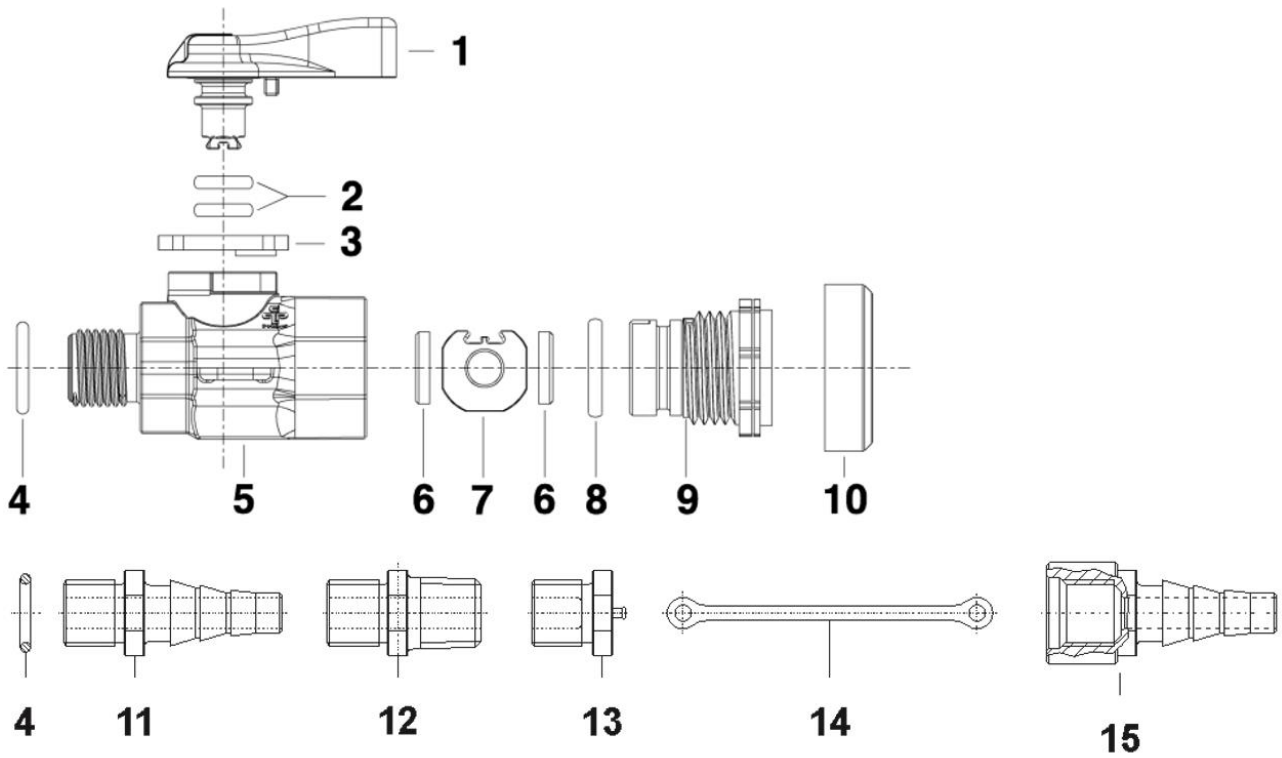

No.	Description	Material
01.	Handle	PVDF
02.	O-ring	FPM
03.	Lock and metering ring	POM
04.	O-ring	FPM
05.	Body	PVDF
06.	Ball seating joint	PTFE
07.	Ball	PVDF
08.	O-ring	FPM
09.	Thrust collar	PVDF
10.	Circlip	POM
11.	Hose nozzle male thread	PVDF
12.	Double nipple	PVDF
13.	Plug	PVDF
14.	Clip tie	
15.	Hose nozzle female thread*	PVDF

*Not included in the accessory set.

Accessories / spare parts

Hose nozzle female thread**

Material

- PVDF

Seal*

- FPM

Norm

- BSP
- NPT



Hose nozzle male thread

Material

- PVDF

Seal*

- FPM

Norm

- BSP
- NPT



Plug

Material

- PVDF

Seal*

- FPM

Norm

- BSP
- NPT



Double nipple

Material

- PVDF

Seal*

- FPM

Norm

- BSP
- NPT



*not included in the scope of delivery
**Not included in the accessory set.

Praher Plastics Austria GmbH

Poneggenstraße 5
4311 Schwertberg
Österreich

T +43 7262 61178-0
F +43 7262 61203
sales@praherplastics.com



<https://youtu.be/05QkA8P7auc>

© Praher Plastics Austria GmbH
Zertifiziert nach / certified acc. to
EN ISO 9001:2015
DB/DEEN/24/07/324D

Diese Druckschrift enthält keine
Gewährleistungszusagen, sondern will lediglich
eine erste Information vermitteln. Das Programm
wird ständig erweitert, daher entsprechen die
Ausführungen und Typen dem Stand bei
Drucklegung. Technische Änderungen
vorbehalten!

This document contains no warranties, but
simply conveys initial information. The program
is constantly expanding and therefore the
versions and types correspond to the state on
the date of printing. Subject to technical
changes!



www.praher-plastics.com